

Instructions to Supervisors for the Unit 3 Practical Examination

CONFIDENTIAL

OPEN ON RECEIPT

The examination will be held on Tuesday 22 January 2002 Morning Session

- These *Instructions* are provided to enable centres to make appropriate arrangements for the examination. Copies of the *Instructions* are to be kept at the centre under lock and key when not in use; they are not to be removed from the centre. The question paper packets must not be opened prior to the examination.
- These instructions explain how to set up the equipment for Question 2.
- Question 2 is printed on pages 3 and 4 of this instruction booklet.
- Centres are at liberty to make any reasonable minor modifications to the apparatus which may be required for the successful working of the experiment but a note of all such modifications must be forwarded to the Examiner with the scripts. However, any such modifications must permit the experiment to be carried out in the specified manner.

Candidates are to investigate the potential difference across parts of a resistor network as the current in the circuit is varied.

Apparatus for circuit required by each candidate:

- dc supply with terminal pd not greater than 5 V, e.g. three 1.5 V 'D-type' cells in good condition, in a suitable holder: this should be connected in series with a single pole, single throw (toggle) switch labelled 'S'
- milliammeter (or equivalent multimeter) with full scale reading not less than 200 mA, capable of reading to 0.1 mA,
- voltmeter (or equivalent multimeter) with full scale reading not less than 2 V, capable of reading to 0.1 V, digital preferred
- 1 k Ω linear (rotary) potentiometer, rated at 0.4 W or greater
- 10 Ω , 22 Ω , 33 Ω , 47 Ω and 68 Ω resistors, 0.5 W or 0.6 W metal or carbon film
- three 4 mm round sockets labelled 'A', 'B' and 'C'
- connecting leads terminated with 4 mm plugs, to assemble the arrangement shown below

The supervisor should assemble the circuit shown in the diagram. This should be concealed from the candidates, e.g., in a suitable box.

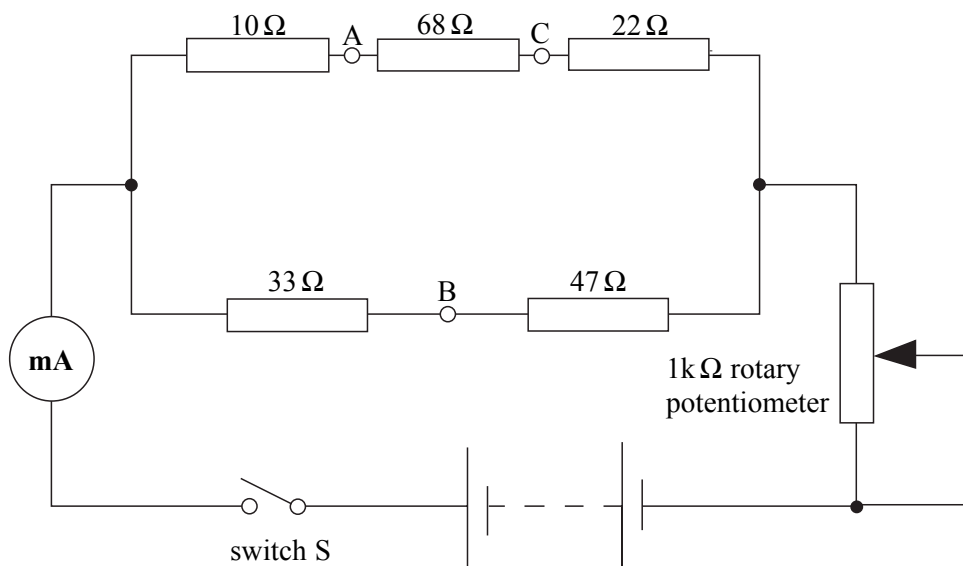

In each arm of the parallel sections of the circuit, a 4 mm round socket forms the common junction between a pair of resistors. These should be clearly labelled 'A', 'B' and 'C', as shown.

The voltmeter should be fitted with colour-coded connecting leads that allow connection to the sockets. This should be placed alongside the circuit.

If multimeters are to be used, the range settings should be checked before the examination and the attention of candidates can be drawn to these settings before the commencement of the experiment.

The examiners require no information for this question.

Question 2 is printed on pages 3 and 4.

In the examination, space is provided for the answer to each part-question. The spaces for candidates' answers have been omitted in this version. The graph paper grid for part (d) has been similarly omitted.

Apparatus

General equipment for the examination may be obtained from:

Philip Harris Education
Novara House
Excelsior Road
Ashby Park
Ashby-de-la-Zouch
Leicestershire
LE65 1NG

Griffin Education
Griffin & George
Bishop Meadow Road
Loughborough
Leicestershire
LE11 5RG

2 This question is divided into parts (a) to (f) printed on pages 8 to 12.

In this experiment you are required to investigate the potential difference across parts of a resistor network as the current in the circuit is varied.

No description of the experiment is required.

You are provided with the circuit shown below and a separate voltmeter.

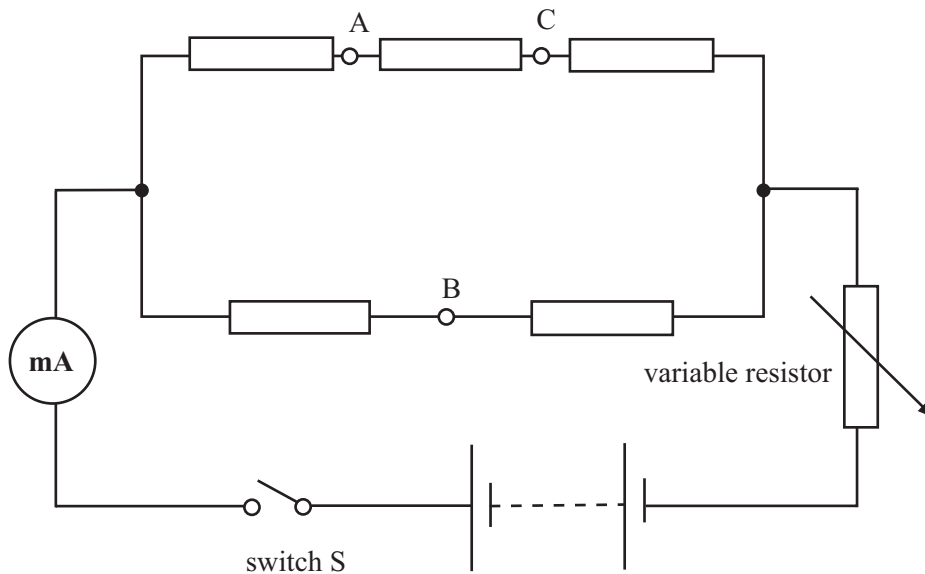

- (a) (i) Close the switch S and set the variable resistor to its **maximum** resistance. Read and record the current I_1 .
- (ii) Set the variable resistor to its **minimum** resistance and read and record the current I_2 .
- (iii) Calculate $\frac{I_2}{I_1}$.

Turn over ►

- (b) Open switch S. Connect the positive lead of the voltmeter to the socket marked A and the negative lead to the socket marked B.
Close switch S, then read and record below the voltmeter reading, V_{AB} , and the current, I , for a range of I values between I_1 and I_2 .
- (c) Open switch S. Connect the positive lead of the voltmeter to the socket marked C leaving the negative lead connected to the socket marked B.
Close switch S, then read and record below the voltmeter reading, V_{CB} , and the current, I , for a range of I values between I_1 and I_2 .

Record all your measurements for part (b) and part (c) in the space below.

Note carefully the sign of the voltmeter readings you record.

(7 marks)

- (d) Using the grid **on page 11** of this booklet, plot a graph of your results. Choose a suitable scale for the vertical axis that will allow all your values for V_{AB} **and** V_{CB} to be plotted **on a single vertical axis** with the corresponding values for I on the horizontal axis.

(6 marks)

- (e) (i) Measure and record the gradient, G_1 , of the graph you plotted for V_{AB} against I .

- (ii) Measure and record the gradient, G_2 , of the graph you plotted for V_{CB} against I .

- (iii) Calculate $\frac{G_1}{G_2}$.

(3 marks)

- (f) (i) Justify the number of readings you took for V_{AB} and V_{CB} .

- (ii) With reference to your experimental results in part (a), suggest how the maximum resistance of the variable resistor compares with the resistance of the network resistors.

- (iii) If the experiment were repeated using a variable resistor of **smaller maximum resistance**, explain what effect, if any, this would have on the values of the currents I_1 and I_2 .

(6 marks)

END OF QUESTIONS